



D25

DRINK MACHINE

"Bubblers" are much more than just a cold drink dispenser, as these circulate the drink from the bottom to the top of the bowl using a pump so that the drink cascades down all sides of the bowl. for great visual merchandising.

The bowls are made of poly carbonate for easy cleaning and long life.

The machine design is easy to use (just pour in the mix and turn on the power).

Features

- Self-contained air cooled countertop model
- Stainless steel allow easier cleaning and less maintenance
- Super-strong, virtually unbreakable polycarbonate bowls and covers give lasting durability
- 1 motor per bowl, 1 switch per bowl - Each bowl operates independently of each other.
- Large 9.5 gallon, dishwasher safe, plastic bowls.

*The D25 is manufactured for Donper USA by a third party.

DONPER USA

Donper USA
500 Stonegate Dr.
Katy, TX 77494

1-844-366-7371
sales@donperusa.com
www.donperusa.com

Side View

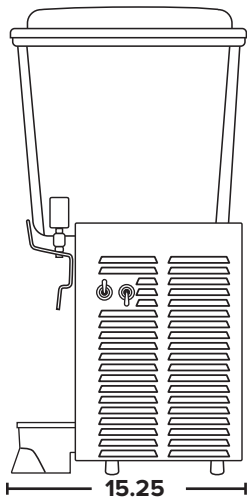

Front View

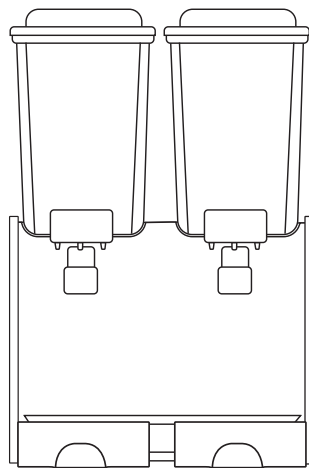

Top View

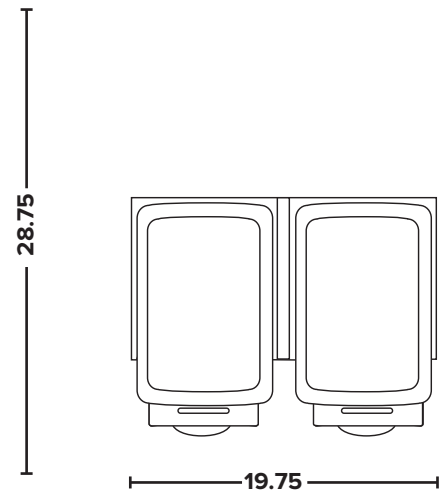

Measurements in inches.

Size and Capacity

Number of Bowls	2
Bowl Capacity (each)	4.75 gallons (18 L)
Total Machine Capacity	9.5 gallons (36 L)
Height	28.75 in (730.25 mm)
Width	19.75 in (501.65 mm)
Depth	15.25 in (387.35 mm)
Weight	75 lbs (35 kg)

Electrical

Voltage	115 v
Phase	Single
Current	3.7 Amps
Compressor	1/3 HP
Hertz	60 Hz Standard US
Plug Type	115 volt Standard Plug

Distributed By:
