



CE ISO 9001

XC336

FROZEN BEVERAGE MACHINE

The XC336 is a high volume slush machine designed for reliability and ease of use in an attractive mirror stainless finish that accents any placement. The XC336 offers an energy efficient refrigeration system for low cost operation, oversized LED backlit signage for merchandising appeal and no heat to melt the slush product, and simple controls for easy operation and perfect slush every time.

Features

- Large 3.2 gallon bowls (x3) for high volume applications
- Night time refrigeration mode for energy savings and to minimize cleaning
- Simple switch control functions for reliability and cost efficient maintenance
- Independently operable bowls for flexibility to run one or two flavors
- Variable consistency control for perfect slush with any product
- Removable drip trays for easy draining and cleaning
- Mirror stainless steel with black trim for an attractive finish that is easy to clean

DONPER USA

Donper USA
500 Stonegate Dr.
Katy, TX 77494

1-844-366-7371
sales@donperusa.com
www.donperusa.com

XC336

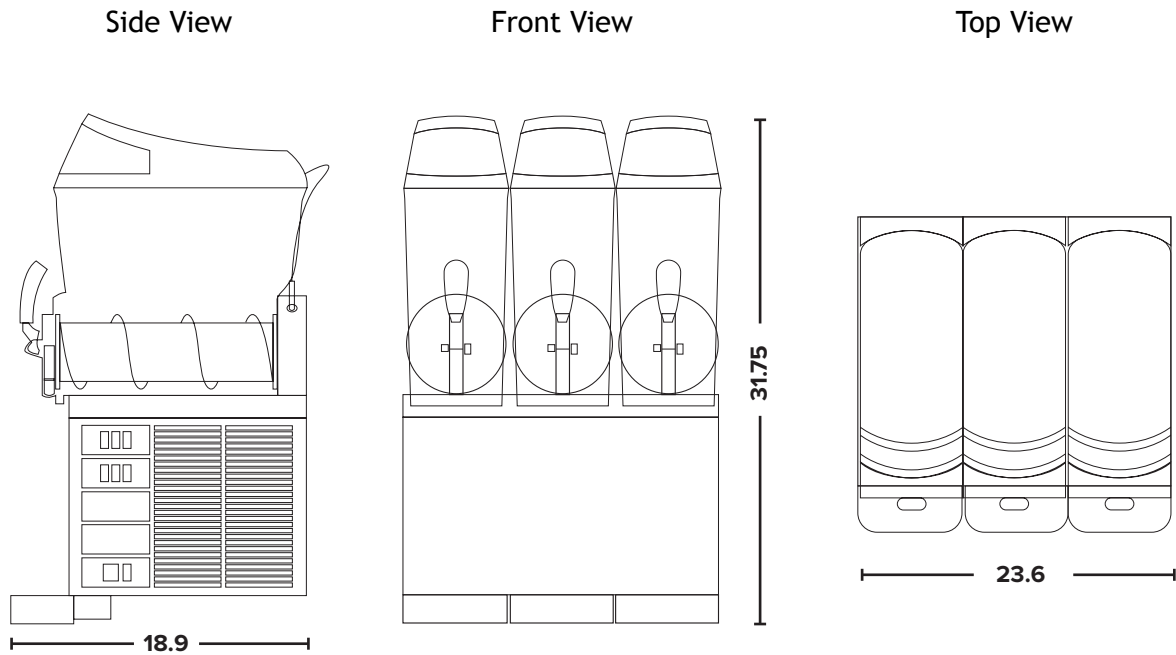

Measurements in inches.

Size and Capacity

| | |
|-----------------------------|-------------------|
| Refrigerated Hoppers (each) | 12.7 Qt (12 L) |
| Height | 31.75 in (806 mm) |
| Width | 23.6 in (600 mm) |
| Depth | 18.9 in (480 mm) |
| Weight | 102 lbs (46 kg) |

Electrical

| | |
|-------------------|------------------------|
| Voltage | 115 v |
| Phase | Single |
| Rated Input Power | 1,100 W |
| Compressor | 1 HP |
| Hertz | 60 Hz |
| Plug type | 115 volt Standard Plug |

Distributed By:

DONPER USA

Donper USA
500 Stonegate Dr.
Katy, TX 77494

1-844-366-7371
sales@donperusa.com
www.donperusa.com